

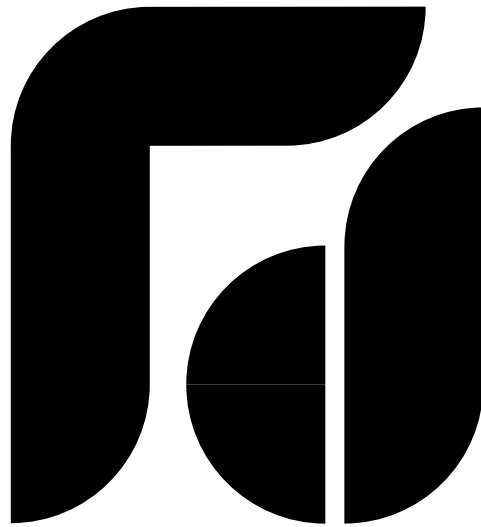

User's Manual



FDC-2220
Self-Tune Fuzzy / PID
Process Temperature Controller



Model: FDC-2220 Instruction Manual

Safety Symbol

The symbol calls attention to an operating procedure, practice, or the like, which, if not correctly performed or adhered to, could result in personal injury or damage to or destruction of part or all of the product. Do not proceed beyond a safety symbol until the indicated conditions are fully understood and met.

CONTENTS

- | | |
|----------------------------|---|
| 1. INTRODUCTION | 5. OPERATION |
| 2. NUMBERING SYSTEM | 6. RE-CALIBRATION |
| 3. SPECIFICATIONS | 7. ERROR MESSAGE & DIAGNOSIS |
| 4. INSTALLATION | 8. COMMON FAILURE CAUSES |

1. INTRODUCTION

The FDC-2220 Fuzzy Logic plus PID microprocessor controller, incorporates a bright, easy to read 4-digit LED display, indicating process value. The Fuzzy Logic technology enables a process to reach a predetermined setpoint in the shortest time, with the minimum of overshoot during power-up or external load disturbance. The units are housed in a 1/32 DIN case, measuring 24 mm x 48 mm with 98mm behind panel depth. The units feature three touch keys to select the various control and input parameters. Using a unique command called "CONFIGURE LEVEL", a supervisor has the flexibility of determining which parameters are accessible by the user. Also the scrolling sequence of parameters are fully configurable according to your requirement. This is particularly useful to OEM's, as it is easy to limit access to suit the specific application.

The FDC-2220 is powered by 20-32VAC/VDC or 90-264VAC supply, incorporating a 3 amp. control relay output and a 3 amp. alarm relay output as standard which can be programmed into Output 2 or dwell timer. Alternative output options include SSR drive, 4-20mA and 0-10 volts. The FDC-2220 is fully programmable for PT100, thermocouple types K, J, T, E, B, R, S, N, 0-20mA, 4-20mA and voltage signal input, with no need to modify the unit.

Digital communications RS-485 or 4-20mA retransmission are available as an additional option. These options allow the FDC-2220 to be integrated with supervisory control systems and software, or alternatively drive remote display, chart recorders or data-loggers.

In last nearly a hundred years although PID control has been used and proved to be an efficient controlling method by many industries, yet the PID is difficult to deal with some sophisticated systems such as second order systems, long time-lag systems, during setpoint change and / or load disturbance circumstance etc. The PID principle is based on a mathematic modeling which is obtained by tuning the process. Unfortunately, many systems are too complex to describe in numerical terms precisely. In addition, these systems may be variable from time to time. In order to overcome the imperfection of PID control, the Fuzzy Technology is introduced. What is the Fuzzy Control? It looks like a good driver. Under different speeds and circumstances, he can control a car well with experiences he had before and does not require the knowledge of kinetic theory of motion. The Fuzzy Logic is a linguistic control which is different from the numerical PID control. It controls the system by experiences and does not need to simulate the system precisely as been controlled by PID.

The basic theory used in this controller is described in the following block diagrams:

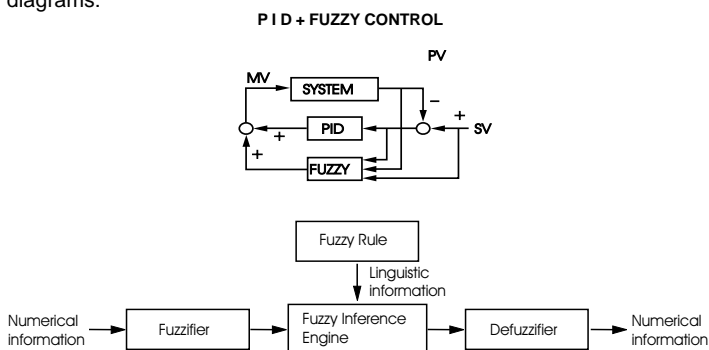

The function of Fuzzy Logic is to adjust the PID parameters internally in order to make the manipulation output value MV more flexible and adaptive to various processes.

The Fuzzy Rule may like these:

- If temperature difference is large, and temperature rate is large, then ΔMV is large.
- If temperature difference is large, and temperature rate is small, then ΔMV is small.
- ⋮
- ⋮
- ⋮

PID + Fuzzy Control has been proven to be an efficient method to improve the control stability as shown by the comparison curves below:

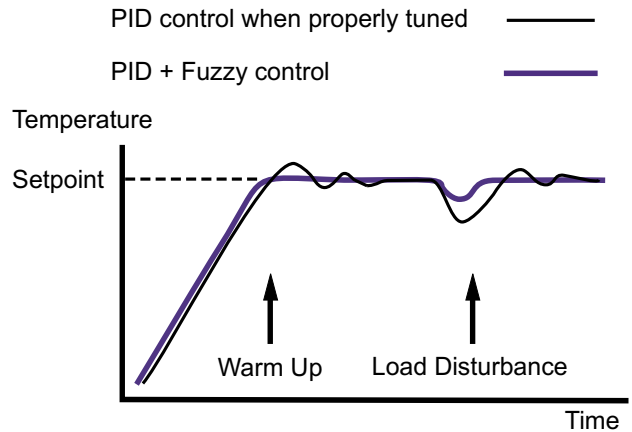

2. NUMBERING SYSTEM

Model No. -

(1) (2) (3) (4) (5) (6) (7) (8)

(1) Power Input

4	90-264VAC
5	20-32VAC/VDC
9	Other

(2) Signal Input

5	Configurable (Universal)
9	Other

(3) Range Code

1	Configurable
9	Other

(4) Control Mode

3	PID/ON-OFF Control
---	--------------------

(5) Output 1 Option

0	None
1	Relay rated 3A/240VAC resistive
2	SSR Drive rated 20mA/24V
3	4-20mA linear, max. load 500 ohms (Module OM92-1)
4	0-20mA linear, max. load 500 ohms (Module OM92-2)
5	0-10V linear, min. impedance 500k ohms (Module OM92-3)
9	Other

(6) Output 2 Option

0	None
---	------

(7) Alarm Option

0	None
1	Relay rated 3A/240VAC resistive
9	Other

(8) Communication

0	None
1	RS-485
2	4-20mA retransmission
3	0-20mA retransmission
9	Other

3. SPECIFICATIONS

INPUT

Sensor	Input Type	Range (°C)	* Accuracy
J	Iron-Constantan	-50 to 999 °C	±2 °C
K	Chromel-Alumel	-50 to 1370 °C	±2 °C
T	Copper-Constantan	-270 to 400 °C	±2 °C
E	Chromel-Constantan	-50 to 750 °C	±2 °C
B	Pt30%RH/Pt6%RH	300 to 1800 °C	±3 °C
R	Pt13%RH/Pt	0 to 1750 °C	±2 °C
S	Pt10%RH/Pt	0 to 1750 °C	±2 °C
N	Nicrosil-Nisil	-50 to 1300 °C	±2 °C
RTD	PT100 ohms (DIN)	-200 to 400 °C	±0.4 °C
RTD	PT100 ohms (JIS)	-200 to 400 °C	±0.4 °C
Linear	4 - 20 mA	-1999 to 9999	±0.05%
Linear	0 - 20 mA	-1999 to 9999	±0.05%
Linear	0 - 1 V	-1999 to 9999	±0.05%
Linear	0 - 5 V	-1999 to 9999	±0.05%
Linear	1 - 5 V	-1999 to 9999	±0.05%
Linear	0 - 10 V	-1999 to 9999	±0.05%

* Accuracy = Linearity Error + Cold Junction Compensating Error + Lead Compensating Error + Offset Drift Error

Linear Voltage Input Impedance: 100 K ohms
Cold Junction Compensation: 0.1 °C / °C ambient typical
Sensor Break Protection: Protection mode configurable
External Resistance: 100 ohms max.
Normal Mode Rejection: 60dB
Common Mode Rejection: 120dB
Sample Rate: 5 times / second

CONTROL

Proportion Band: 0-200 °C (0-360 °F)
Reset (Integral): 0-3600 seconds
Rate (Derivative): 0-1000 seconds
Ramp Rate: 0-55.55 °C (99.99 °F) / minute
Dwell: 0-9999 minutes
ON-OFF: With adjustable hysteresis 0-11.0 °C (0.1-19.9 °F)
Cycle Time: 0-99 seconds
Control Action: Direct (for cooling) and reverse (for heating)

POWER

Rating: 90-264VAC, 50 / 60 Hz
Consumption: Less than 5VA

ENVIRONMENTAL & PHYSICAL

Safety: UL , CSA, CE
Protection: NEMA 4X, IP65
EMC Emission: EN50081-1, EN55011
EMC Immunity: IEC801-2, IEC801-3, IEC801-4
Operating Temperature: -10 to 50 °C
Humidity: 0 to 90% RH (non-condensing)
Insulation: 20M ohms min. (500 VDC)
Breakdown: AC2000V, 50 / 60Hz, 1 minute
Vibration: 10-55Hz, amplitude 1mm
Shock: 200 m / s² (20g)
Moldings: Flame retardant polycarbonate
Weight: 110 grams

4. INSTALLATION

! Dangerous voltages capable of causing death are sometimes present in this instrument. Before installation or beginning any trouble shooting procedures the power to all equipment must be switched off and isolated. Units suspected of being faulty must be disconnected and removed to a properly equipped workshop for testing and repair. Component replacement and internal adjustments must be made by qualified maintenance personnel only.

! To help minimize the possibility of fire or shock hazards, do not expose this instrument to rain or excessive moisture.

! Do not use this instrument in areas subject to hazardous conditions such as excessive shock, vibration, dirt, moisture, corrosive gases or oil. The ambient temperature of the areas should not exceed the maximum rating specified in Section 3.

4.1 UNPACKING:

Upon receipt of the shipment remove the instrument from the carton and inspect the unit for shipping damage. If any damage due to transit is noticed, report and file a claim with the carrier. Write down the model number, serial number, and date code for future reference when corresponding with our service center. The serial number (S/N) and date code (D/C) are located inside the control.

4.2 MOUNTING

Make panel cutout to dimension shown in Figure 4.1.

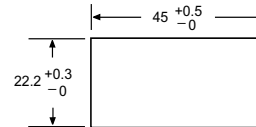
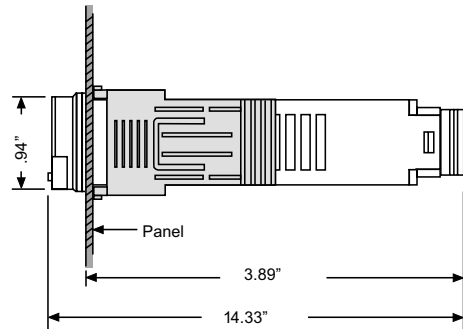

Fig. 4.1 Mounting dimensions

(a) The clamp for quick mounting:

Take the clamp away and insert the controller into panel cutout install the clamp back and push it forward till the controller firmly onto the panel.



(b) The clamps for protection NEMA 4X / IP65:

Take both mounting clamps away and insert the controller into panel cutout. Install the mounting clamps back. Gently tighten the screws in the clamp till the controller front panel is fitted snugly in the cutout.

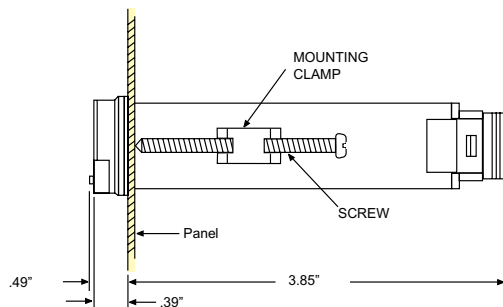

4.3 WIRING PRECAUTIONS

- * Before wiring, verify the label for correct model number and options. Switch off the power when checking.
- * Care must be taken to ensure that maximum voltage ratings specified in Section 3 are not exceeded.
- * It is recommended that power to these instruments be protected by fuses or circuit breakers rated at the minimum value possible.
- * All units should be installed inside a suitably grounded metal enclosure to prevent live parts being accessible to human hands and metal tools.
- * All wiring must conform to appropriate standards of good practice and local codes and regulations. Wiring must be suitable for voltage, current, and temperature ratings of the system.
- * The "stripped" leads as specified in Figure 4.2 below are used for power and sensor connections.
- * Take care not to over-tighten the terminal screws.

* Unused control terminals should not be used as jumper points as they may be internally connected, causing damage to the unit.

* Verify that the ratings of the output devices and the inputs as specified in Table 4.1 on are not exceeded.

* Electric power in industrial environments contains a certain amount of noise in the form of transient voltages and spikes. This electrical noise can enter and adversely affect the operation of microprocessor-based controls. For this reason we strongly recommend the use of shielded thermocouple extension wire which connects from the sensor to the controller. This wire is a twisted-pair construction with foil wrap and drain wire. The drain wire is to be attached to ground at one end only.

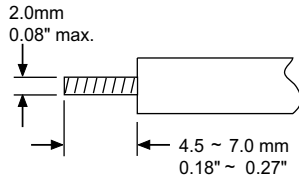

Fig. 4.2 Lead Termination

4.4 CONNECTION AND WIRING

The following connections for outputs and inputs are provided at the rear of the controller housing:

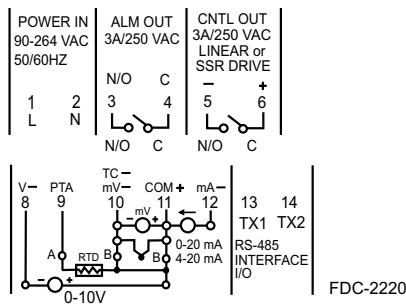

Fig. 4.3 Rear Terminal Connections

4.4.1 Mains (Line) Input

The controller is supplied to operate on 24V (20-32VAC/VDC) or 90-264VAC. Check that the installation mains voltage corresponds to that indicated on the product label before connecting power to the controllers.

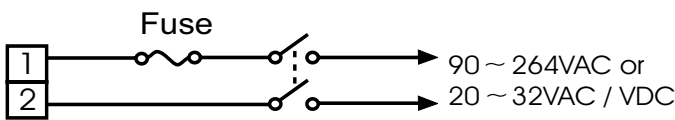

Fig. 4.4 Mains (Line) Supply Connections

! This equipment is designed for installation in an enclosure which provides adequate protection against electric shock. The enclosure must be connected to earth ground.

Local requirements regarding electrical installation should be rigidly observed. Consideration should be given to the prevention of unauthorised personnel from gaining access to the power terminations.

4.4.2 Thermocouple Input

Thermocouple input connections are shown in Figure 4.5. The correct type of thermocouple extension lead-wire or compensating cable must be used for the entire distance between the controller and the thermocouple, ensuring that the correct polarity is observed throughout. Joints in the cable should be avoided, if possible.

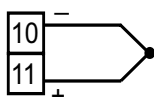

Fig. 4.5 Thermocouple Input Connections

The colour codes used on the thermocouple extension leads are shown in Table 4.1.

TABLE 4.1 THERMOCOUPLE CABLE COLOUR CODES

Thermocouple Type	Cable Material	British BS	American ASTM	German DIN	French NFE
T	Copper Constantan	+ white - blue * blue	+ blue - red * blue	+ red - brown * brown	+ yellow - blue * blue
J	Iron / Constantan	+ yellow - blue * black	+ white - red * black	+ red - blue * blue	+ yellow - black * black
K	Nickel Chromium Nickel Aluminium	+ brown - blue * red	+ yellow - red * yellow	+ red - green * green	+ yellow - purple * yellow
R S	13% Copper 10% Copper Nickel	+ white - blue * green	+ black - red * green	+ red - white * white	+ yellow - green * green
B	Platinum / Rhodium		+ grey - red * grey		

* Colour of overall sheath

4.4.3 PT100 Ohm RTD Input

RTD connection are shown in Figure 4.6, with the compensating lead connected to terminal 11. For two-wire RTD inputs, terminals 10 and 11 should be linked. The three-wire RTD offers the capability of lead resistance compensation provided that the three leads should be of same gauge and equal length.

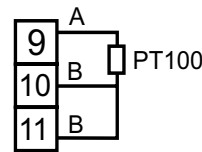
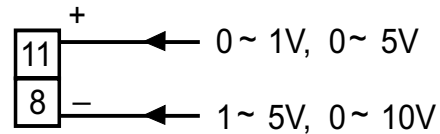

Fig. 4.6 RTD Input Connections

4.4.4 DC Linear Input

DC linear voltage and linear current connections are shown in Figure 4.7 and Figure 4.8.



Input Impedance = 100k ohm

Fig. 4.7 Linear Voltage Input Connections

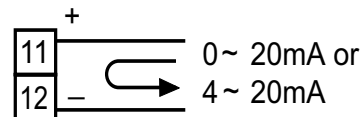

Fig. 4.8 Linear Current Input Connections

4.4.5 Relay Output Direct Drive

Figure 4.9 shows connections using the internal relay to drive a small load. The current does not exceed 3 amperes.

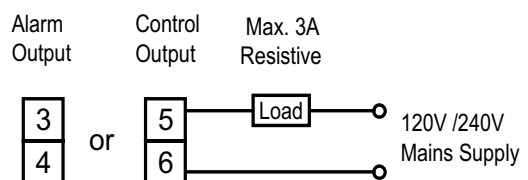

Fig. 4.9 Relay Direct Drive Connections

4.4.6 Relay Output Contactor Drive

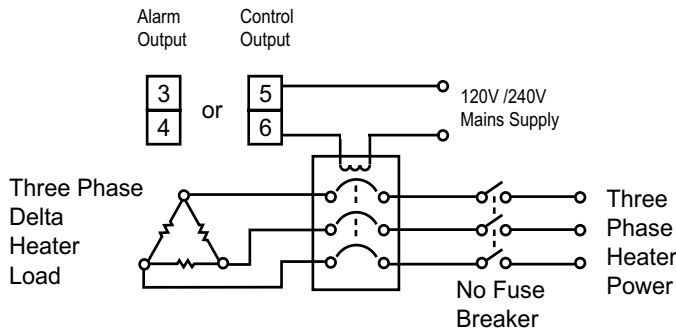

Fig. 4.10 Contactor drive Connections

4.4.7 SSR Drive Output

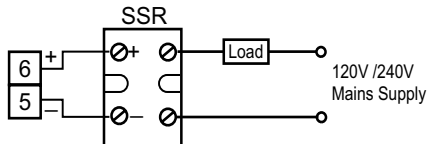

Fig. 4.11 SSR Drive Connections

Controllers fitted with the SSR drive output produce a time-proportional non-isolated pulse voltage (0-20V nominal, output impedance 660 ohms). The connections are shown in Figure 4.11

4.4.8 Linear Output

There are three types of linear output modules (See Section 2) can be selected for control output (OUT 1). The connections are shown in Figure 4.12.

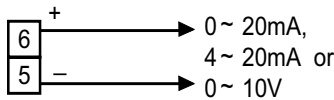

Fig. 4.12 Linear Voltage / Current Connections

4.5 SENSOR PLACEMENT

Proper sensor placement can eliminate many problems in a control system. The probe should be placed so that it can detect any temperature change with minimal thermal lag. In a process that requires fairly constant heat output, the probe should be placed close to the heater. In processes where the heat demand is variable, the probe should be closer to the work area. Some experimenting with probe location is often required to find this optimum position.

In a liquid process, addition of a stirrer will help to eliminate thermal lag. Since the thermocouple is basically a point measuring device, placing more than one thermocouple in parallel will provide an average temperature reading and produce better results in most air heated processes.

Proper sensor type is also a very important factor in obtaining precise measurements. The sensor must have the correct temperature range to meet the process requirements. In special processes the sensor might have to have different requirements such as leak-proof, anti-vibration, antiseptic, etc.

Standard sensor limits of error are ± 4 degrees F (± 2 degrees C) or 0.75% of sensed temperature (half that for special) plus drift caused by improper protection or an over-temperature occurrence. This error is far greater than controller error and cannot be corrected at the sensor except by proper selection and replacement.

5. OPERATION

5.1 FRONT PANEL DESCRIPTION

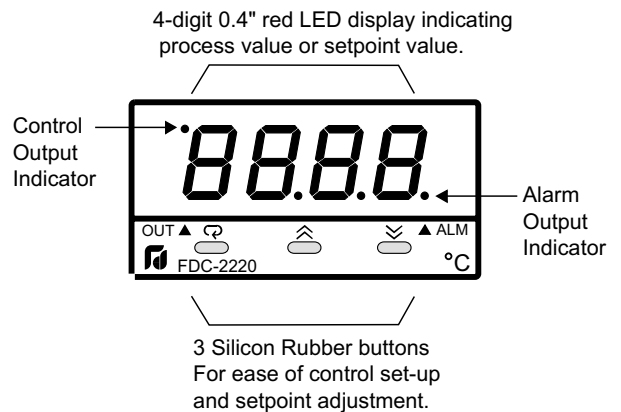

5.2 KEYPAD OPERATION

* With power on, it has to wait for 12 seconds to memorize the new values of parameters once it been changed.

TOUCHKEYS	FUNCTION	DESCRIPTION
	Up Key	Press and release quickly to select the desired digit of a numerical parameter to change. Press and hold to increase the value of the selected digit for a numerical parameter or to change the selection for an index parameter.
	Down Key	Press and release quickly to select the desired digit of a numerical parameter to change. Press and hold to decrease the value of the selected digit for a numerical parameter or to change the selection for an index parameter.
	(Direct) Scroll Key	Select the parameter in a direct sequence. Also used to select the tool program parameters.
Press for at least 3.2 seconds	Long Scroll / Enter Key	Select the protected parameters in higher security level, also used to actuate the execution for the selected tool program whenever the display is showing a tool program.
Press and	Reverse Scroll / Calibration Verification Key	Select the parameter in a reverse sequence during parameter scrolling, or verify the display accuracy for various input types during the calibration mode.
Press and for at least 3.2 seconds	Lock Key	Disable keypad operation to protect all the parameters from tampering.
Press and	Tool Program Key	Select the tool program in sequence.
Press and	Reset / Exit Key	Unlock keypad operation and reset the front panel display to a normal display mode, also used to leave the tool program execution or ending the autotune and manual control execution.
Press and for at least 3.2 seconds	Autotune Key	Press and hold both keys for at least 3.2 seconds then release to start execution of autotune program.
Press and	Engineering Key	By entering correct security code to allow execution of engineering programs. This function is used only in the factory to speed up the production. The user should never attempts to operate this function.

5.3 FLOW CHART OF PARAMETERS

The following chart shows a typical (default) access sequence of parameters. Note 1 shows how to modify the display sequence and how to delete unused parameters.

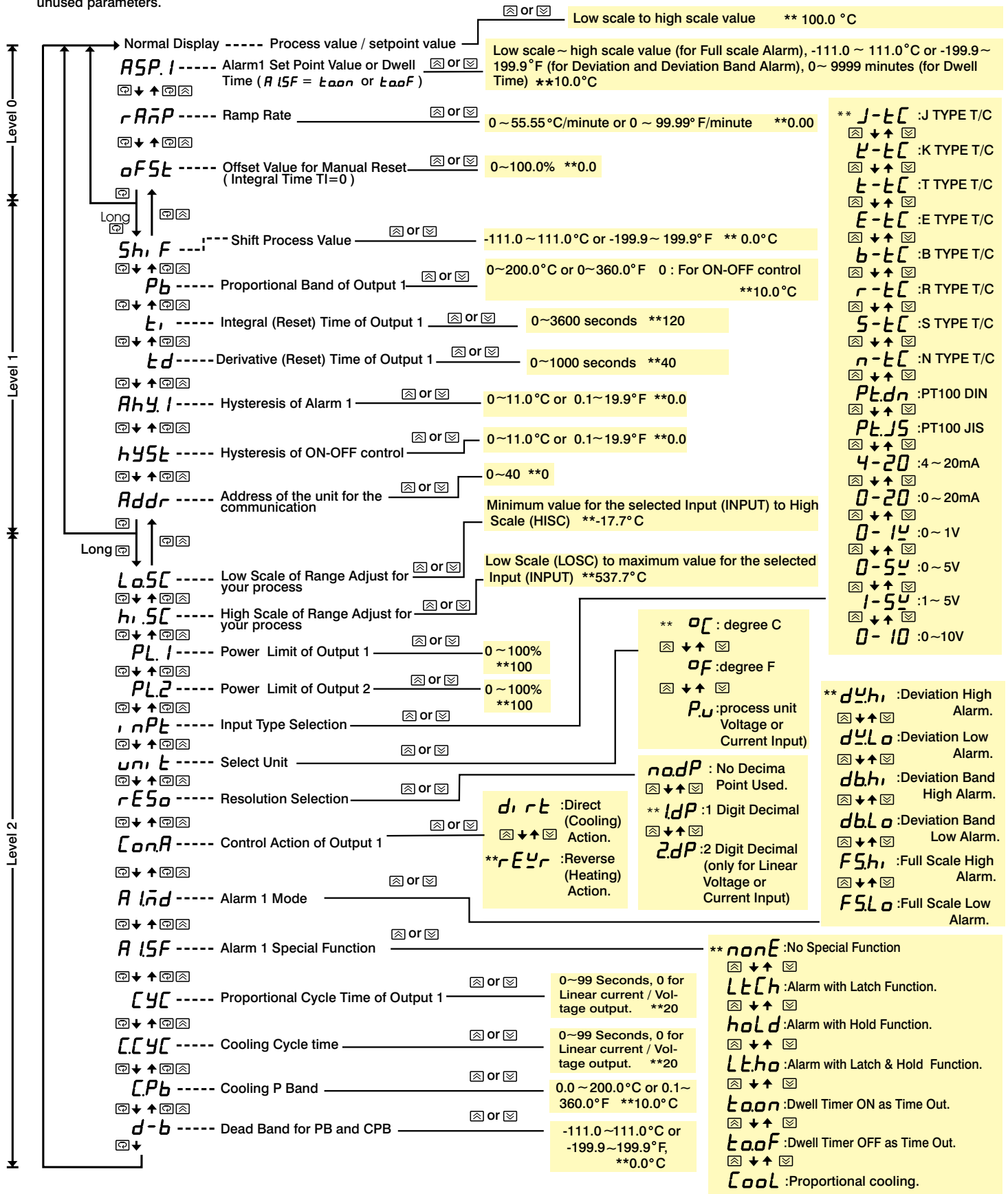

Note 1: Using the Tool Program (Refer to sec .5.4 and sec. 5.6.5 for the configuration of security level) the display sequence and the security level for any parameter are configurable. Also any unused parameter can be removed from the display sequence to simplify the operation.

Note 2: Using long scroll key (press and hold [] for at least 3.2 seconds) to select parameters in higher security level.

Note 3: To change the value of a numerical parameter (the value of which is denoted by a number) press and release the [] or [] key to select the desired digit, then press and hold the [] or [] key to change the value of the value selected digit. To change the value of an index parameter (the value of which is abbreviated by letters) press and hold the [] or [] key to select the desired value.

** : Denotes the default setting.

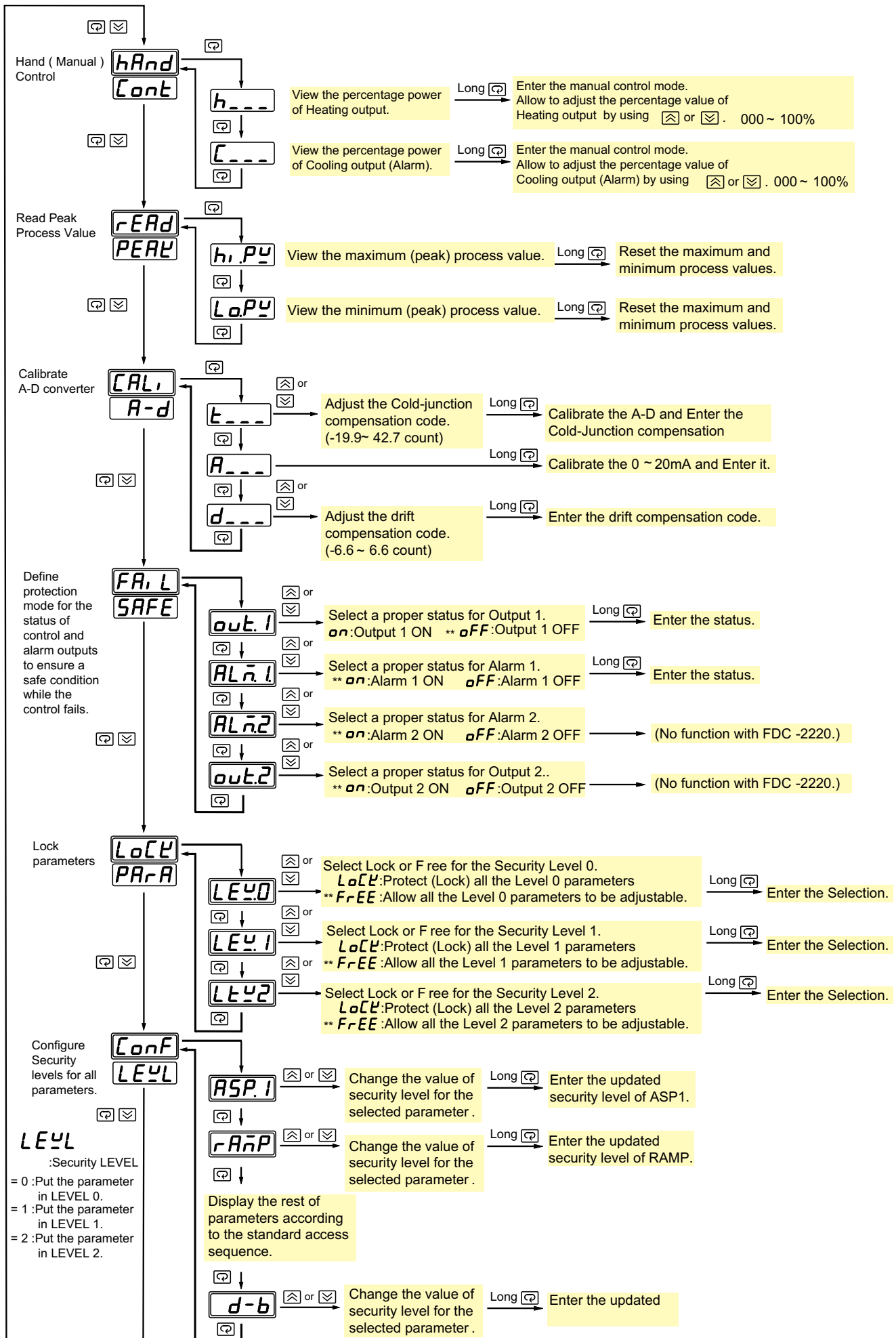

5.4 FLOW CHART OF TOOL PROGRAMS



5.5 SETTING-UP PROCEDURES

As power applied, the model number of the controller and its software version number will be displayed for 3.2 seconds, then all the display segments and LED indicators will be lit for 3.2 seconds. After the 6.4 seconds of initial cycle the controller enters the normal display mode, the display shows the current process value and the alternative display shows the setpoint value. The display will continuously flash in cases of:

- (1) during executing autotune program
- (2) during executing manual mode program
- (3) warning that the next parameter is a higher level parameter as scroll key is depressed. The warning message will maintain a duration of 3.2 seconds. If the scroll key is released after the duration elapses the display will indicate the code of next parameter (in the display) and its value (in the alternative display), otherwise, the display will return to normal mode to indicate process value and setpoint value.

The display will blink a moment as a new value of parameter is written into the non-volatile memory. The display is also used to indicate the error messages in case of abnormal condition occurs. Subsequently, each depression of the scroll key will step down the controller through the default sequence of displays shown in Table of section 5.3. If unfortunately the desired parameter passed on the display, it can still be retained by pressing  and  to prevent frustration. The sequence of displays can be reconfigured by changing the security level of parameters as described in subsequent section.

5.5.1 Learning the Parameters

SV - Setpoint Value

This parameter is the desired target of the process. It can be adjusted within the range defined by the Low Scale Value (LOSC) and High Scale Value (HISC). The default value is 100°C (212°F).

ASP1 - Alarm 1 Setpoint Value or Dwell Time

This sets the levels at which the alarm 1 will operate if AISF is selected for alarm function. If AISF is selected for dwell timer (*taon* or *taof*), ASP1 is used as setting value of dwell timer. The timer start to count as the process value reaches the setpoint value, see section 5.10 and 5.13 for more details.

RAMP - Ramp Rate

This forces the process to warm up (or cool) with a predetermined rate as power applied. Setting this parameter to zero if no ramp is needed. The process will warm up (or cool) with maximum speed.

OFST - Offset Value for Manual Reset

For those systems it is desired to perform manual reset control by setting integral time (TI) to zero, OFST is adjusted to compensate the deviation between PV and SV. If PV is too low for reverse control action (or too high for direct control action) then increase value of OFST. If TI is not zero, OFST is unchangeable.

SHIF - Shift Process Value

This value will be added to the process value so that the process value will be read with minimum error. For those process with bad circulation may use this parameter to compensate the temperature difference between sensor and the process.

PB, TI, TD - Constants for PID Control

Refer section 5.7 for an in-depth description.

AHY1 - Hysteresis Values of Alarm 1

These values define the dead bands for alarm action. As the process value exceeds the boundary of the dead band and stays within the band the alarm will remain same status.

HYST - Hysteresis Value of ON-OFF Control

This parameter defines a dead band for the ON-OFF control.

ADDR - Address of the unit for the communication

This parameter provides an identity code for the RS-485 interface. Note that it is not allowable to set the same ADDR code for those controllers communicating with same computer to prevent line contention problems. If the controller does not use the RS-485 interface, the ADDR can be neglected.

LOSC, HISC - Low / High Scale Range

If thermocouple or PT100 is selected as input type (INPT) these parameters are used to define the range of the setpoint adjustment. Otherwise, if linear process input is selected, these parameters are used to define the range of the process value and setpoint adjustment, refer section 5.14 for more details.

PL1, PL2 - Power limit for Heating and Cooling Outputs

These parameters limit maximum heating and cooling percentage power during warm up and in proportional band. These are used only for those processes that heat or cool with full speed are dangerous or not satisfactory with the results. For normal applications these parameters are set to 100%.

INPT - Input Type selection

Select a correct type in accordance with the input connection.

UNIT - Process Unit

Select a correct unit for the process. for linear process input select Pu (Process Unit) if the unit is other than °C or °F.

RESO - Select Decimal Point Position (Resolution)

This parameter defines the position of the decimal point on the process value and setpoint.

Value	Decimal Point Position
<i>noDP</i>	xxxx
<i>1dP</i>	xxx.x
<i>2dP</i>	xx.xx

Note that *2dP* is used only for linear process input.

CONA - Control Action of Output 1

Select *revr* (Reverse) action for heating process, that is to increase output power as the process value decreases (or setpoint increases). Select *dir* (Direct) action for cooling process, that is to increase output power as the process value increases (or setpoint decreases).

A1MD - Alarm Mode Selection for Alarm 1

Refer section 5.10 for an in-depth description.

A1SF - Alarm 1 Special Function

Select a hold function or latch function for Alarm 1. See section 5.10 for more details. Select *taon* or *taof* to reconfigure Alarm 1 output as a dwell timer. See section 5.13 for more details.

CYC, CCYC - Proportional Cycle Time of Output 1 and Cooling Output

Select a proper value for the process in accordance with the output devices fitted. See section 5.5.2 for further discussion.

CPB, DB - Cooling P Band, Cooling Dead Band

Refer section 5.9 for description. If no cooling is fitted for the controller, these parameters may be neglected.

5.5.2 Initial Setup

Access the keypads to view the value of each parameter. For an undesirable value of parameter perform up and down key to obtain a correct value, then proceed to the next parameter until all parameters are verified. Note that the new value of parameters are entered into nonvolatile memory automatically.

The adjustment of proportional cycle time (CYC and CCYC) is related to the speed of process response and the output device fitted. for a faster process it is recommended to use SSR (to select SSR Drive Output) or SCR (to select linear current or voltage output) to drive the load. The relay output is used to drive magnetic contactor in a slow process. If a long cycle time is selected for a fast process an unstable result may occur. Theoretically the smaller the cycle time is selected, the better control can be achieved. But for relay output, the cycle time should be as large as possible (consistent with satisfactory control) in order to maximize relay life.

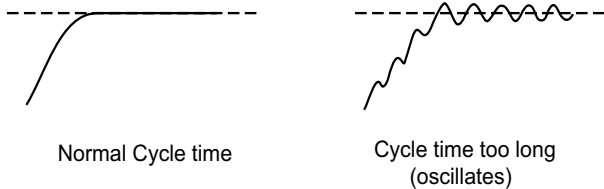

The follow table provides cycle time recommendations to avoid premature relay failure:

Output Device (OUT1 or Cooling Output)	Cycle Time (CYC or CCYC)	Load (resistive)
Relay	20 sec or more recommended 10 sec. minimum	2A / 250VAC or contactor
	5 sec. minimum	1A / 250VAC
Solid State Relay Drive	1- 3 sec.	SSR
Linear Current / Voltage	0.1 sec.	Phase control module

Note: For an ON-OFF control (by setting PB = 0) the cycle time selection may be ignored.

5.5.3 FAIL-SAFE Configuration

FAIL-SAFE is a Tool Program used to define an ON or OFF status of failure for Output 1 (OUT1), Alarm 1 Output (ALM1). Press and , then release both keys until FAIL-SAFE is viewed in the display windows. Then press scroll key to obtain the desired output which is shown in the display. Now press and hold up or down key to change the status which is shown in the display. Note that if the desired value is different from the original one, a long scroll (pressing scroll key 3.2 sec.) has to be operated to enter the new value before proceeding to the next Tool Parameter . If the FAIL-SAFE status is not critical for a process as the controller fails, the configuration of this section can be omitted.

5.5.4 LOCK Parameter

According to the flow chart shown in section 6.4, one can reach LOCK PARA and obtain LEVEL ($LE4.0 \sim LE4.2$) which is shown in the display and the Lock status (LOCK or FREE) is shown in the display. For example, if we select LOCK for $LE4.2$ and press scroll key 3.2 seconds to enter the selection, then all the parameters configured in level 2 can not be changed. A LOCK message will be indicated in display if one attempts to change a locked (protected) parameter.

5.5.5 Configure Security Levels of Parameters

The user of the controller may often complain that the operation is so complicated, most of parameters are unused for them and it takes long time to get a parameter to access. You will no longer worry about this. One of the versatile functions of this controller is that the security level for each parameter can be redefined arbitrarily. One of four levels (Level 0, Level 1, Level 2 and Level 3) can be assigned to any parameter. The parameters with lower level will be displayed before those parameters with higher level as one performs scroll key. Furthermore, the level 3 parameters will never be displayed on the front panel. Hence the user can assign level 3 to those unused parameters and assign level 0 to those most frequently used parameters according to his requirements. Then the unused parameter will never appear on the display to avoid confusion and the display sequence of parameters is reconfigured.

To configure level for each parameter one can follow the flow chart in section 6.4 by pressing and keys to reach **CONF LEVEL**, then perform key to get the desired parameter. The display indicates the level of the parameter. Now one can change the level value for that parameter by using up key or down key. Finally press and hold 3.2 seconds or longer, now the new level value is entered. If the

level value is unchanged the above operation for entering can be omitted. For example: If ASP1, RAMP are configured as level 0, PB, TI, TD are configured as level 1, and the other parameters are configured as level 3, the scrolling sequence of parameters will be as follows:



5.6 AUTO-TUNE

The process is tuned at setpoint. The process will oscillate about the setpoint during auto-tune. Set a setpoint to a lower value if overshoot beyond the normal process value is likely to cause damage.

The auto-tune program is applied during:

- * Initial set-up
- * The setpoint is changed substantially from the previous auto-tune
- * The control result is unsatisfactory

The auto-tune procedures:

- * To ensure that all parameters are configured correctly.
- * To ensure that PB is not zero because that ON-OFF control is not allowable to perform auto-tune.
- * Set the setpoint to the normal operating process value (or to a lower value if overshoot beyond the normal process value is likely to cause damage) and use normal load conditions.
- * Press and hold both up and down keys for 3.2 seconds then release together. The display is flashing during execution of auto-tune program.

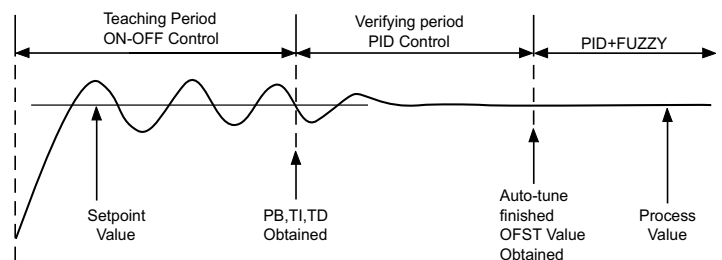

Auto-tune " teaches " the controller the main characteristics of the process. It " learns " by cycling the output on and off. The results are measured and used to calculate optimum PID values which are automatically entered in nonvolatile memory.

During the second period of auto-tune the controller performs PID control to verify the results and finally an OFST value is obtained and entered in the memory.

To stop the auto-tune, press both up and down key then release together, the display will stop to flash. But if the controller has entered in the verifying period, the display will continue to flash until auto-tune is finished.

5.7 TUNING THE CONTROLLER MANUALLY

- * To ensure that all parameters are configured correctly
- * Set PB to zero. Set HYST to the smallest (0 °C or 0.1 °F)
- * Set the setpoint to the normal operating process value (or to a lower value if overshoot beyond the normal process value is likely to cause damage) and use normal load conditions.
- * Switch on the power supply to the heater. Under these conditions, the process value will oscillate about the setpoint and the following parameters should be noted:

- (1) The peak to peak variation (P) of the first cycle in °C or °F (i.e. the difference between the highest value of the first overshoot and the lowest value of the first undershoot).

(2) The cycle time (T) of this oscillation in seconds (see following Figure).

* The control setting should then be adjusted as follows:

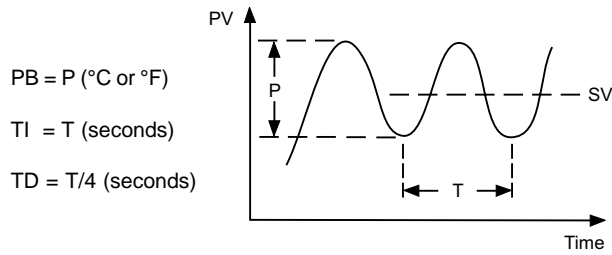

The PID parameters determined by the above procedures are just rough values. If the control results by using above values are unsatisfactory, the following rules may be used to further adjust the PID parameters:

ADJUSTMENT SEQUENCE	SYMPTON	SOLUTION
(1) Proportional Band (P) PB	Slow Response	Decrease PB
	High overshoot or Oscillations	Increase PB
(2) Integral Time (I) TI	Slow Response	Decrease TI
	Instability or Oscillations	Increase TI
(3) Derivative Time (D) TD	Slow Response or Oscillations	Decrease TD
	High Overshoot	Increase TD

Effect of PID adjustment on process response:

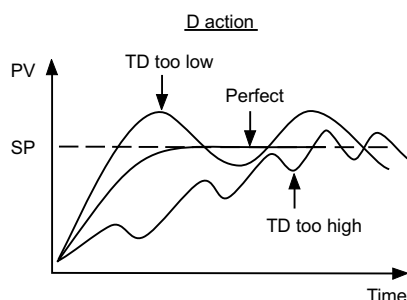
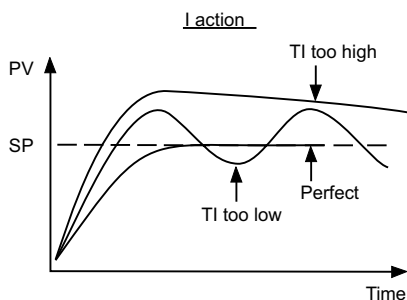
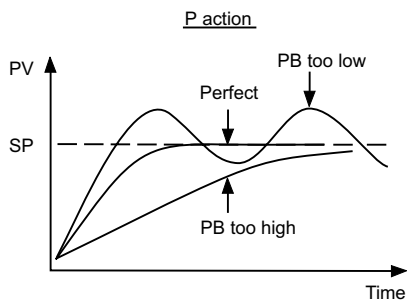

5.8 ON-OFF CONTROL

The alarm output if configured as alarm function performs an ON-OFF control basically. Adjust the P band to $PB = 0$, an additional channel of ON-OFF control with variable hysteresis is obtained. Hysteresis is measured with degree. It is also named differentials or deadband sometimes. Refer to following Figure for the description of ON-OFF control.

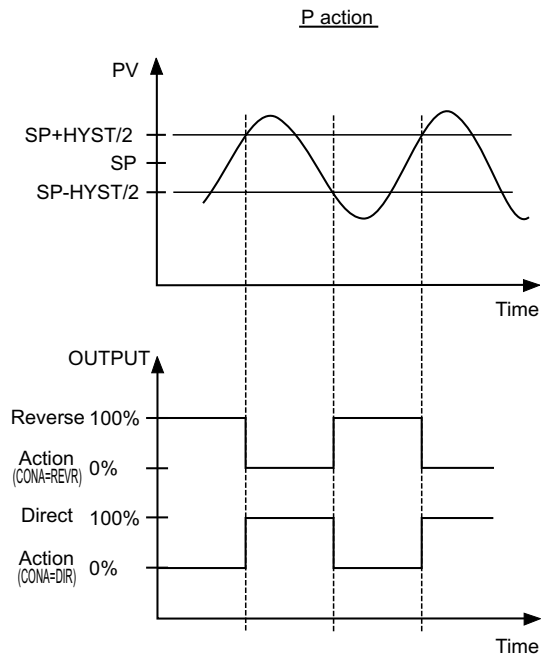

ON-OFF control may introduce excessive process variation even if the hysteresis is minimized to the smallest. If the ON-OFF control is set, parameters TI, TD and CCT will have no effect on the system, nor can the manual mode and the auto-tune program be executed.

5.9 COOLING CONTROL

Cooling Control Options:

Output Configurations	Heating Output	Cooling Output	Adjustment of Parameters
ON-OFF Cooling (No Heating)	None	OUT1	CONA = DIRT HYST SV
Proportional Cooling (No Heating)	None	OUT1	CONA = DIRT PB, TI, TD, CYC, SV
Heating + ON-OFF Cooling	OUT1	ALM1	CONA = REVR A1SF = NONE A1MD = DVHI (or FSHI) AHY1, SV (or ASP1)
Heating + Proportional Cooling	OUT1	ALM1	CONA = REVR A1SF = COOL CPB, DB, CCYC, SV

Functions of CPB and DB:

The cooling P band CPB and dead band DB are measured in degree.

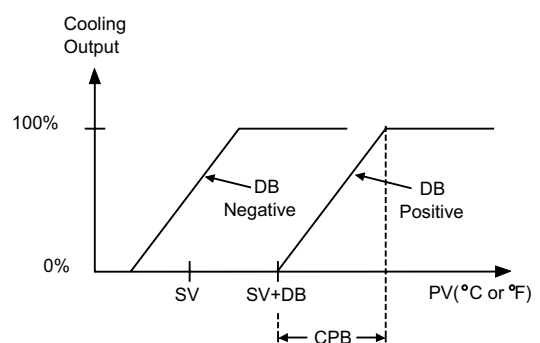

5.10 ALARM

There is a independent alarm available by adjusting the alarm special function A1SF and A2SF. The following descriptions of this section are based on Alarm 1.

- No special function: A1SF = **none**

Alarm on

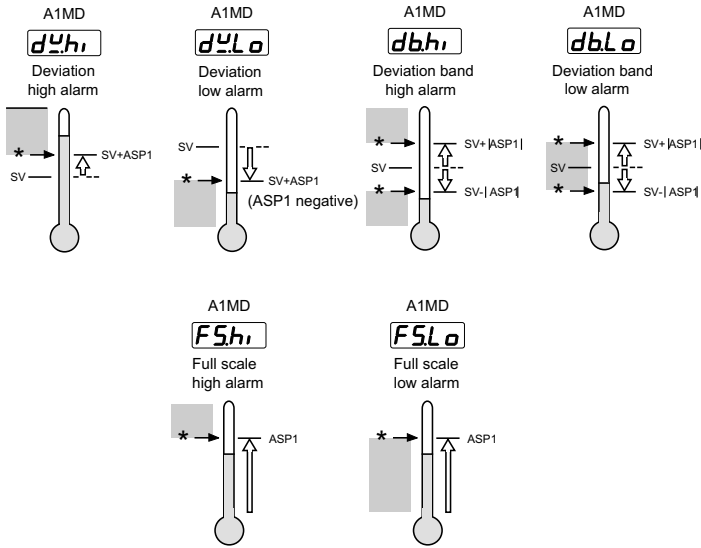

- * Latch Alarm: A1SF = **LtCh**

When selected, the alarm output and indicator latch as the alarm occurs. The alarm output and indicator will be energized even if the alarm condition has been cleared unless the power is shut off.

- * Hold Alarm: A1SF = **hold**

When selected, in any alarm mode, prevents an alarm on power up. The alarm is enabled only when the process value reaches setpoint value (SV).

Example: Hold function used with deviation low alarm

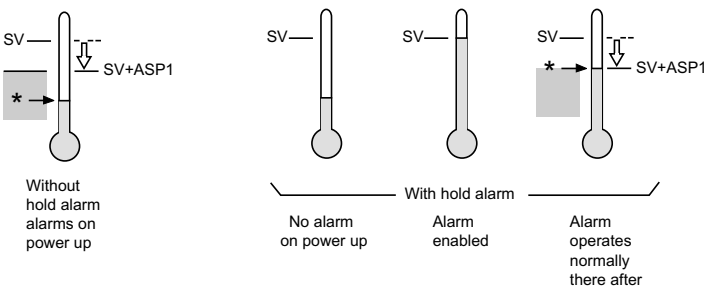

- * Latch & Hold Alarm: A1SF = **LtCh**

When selected, in any alarm mode, prevents an alarm on power up. The alarm is enabled only when the process value reaches setpoint value (SV). Thereafter, the alarm acts as a latch alarm described above.

- * Hysteresis (AHY1) adjustment

Example: No special function used with deviation high alarm, SV = 100 °C, ASP1 = 10 °C, AHY1 = 4 °C

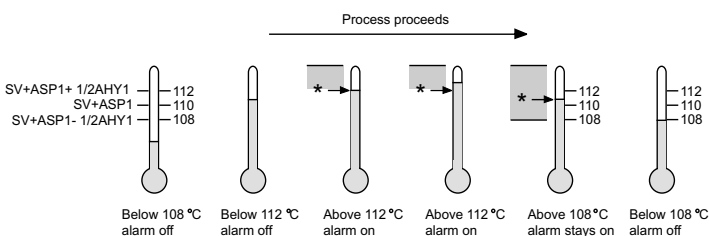

5.11 VIEWING THE OUTPUT PERCENTAGE POWER

Selecting the Tool Programs until the HAND CONTROL **hRnd** **Cont** is obtained. Press scroll key, the display will show the process value and the display will show the percentage power of output 1 such as **H 64**. To view the cooling output, press scroll key again. The lower display will show the percentage power of alarm 2 such as **C 27**, if alarm 2 is reconfigured as cooling output (A2SF = COOL). If alarm 2 is configured as alarm, the percentage power is invalid and should be ignored.

The range of the output percentage power is within 0 and 100 (%). If an on-off control is selected, only 0 and 100 are displayed. For a proportional control, the output percentage power represents the duty cycle of the output ON-state.

Example: **H 40** is viewed with cycle time CYC = 10 sec. The output 1 act as follows:

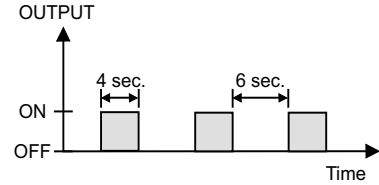

5.12 MANUAL CONTROL

Following the procedure as in section 5.11, then press and hold the scroll key for 3.2 seconds and release, the controller will enter the manual control mode. The display begins to flash. The output percentage power can be adjusted by using up or down keys. Note that for an on-off control with PB = 0, the manual control is not allowable to be used. An error message **oPEr** will be shown in the display.

The manual control is used during:

- * Teaching the process
- * The controller fails

! The manual control is an open loop control. The process may rise to a dangerous value (temperature). Special attention to the process has to be given to prevent a system damage.

5.13 RAMP & DWELL

The controller can be configured to act as either a fixed setpoint controller or as a single ramp controller on power up. This function enables the user to set a predetermined ramp rate (RAMP) to allow the process to gradually reach setpoint temperature thus producing a "soft start" function.

A dwell timer is incorporated within the controller and the alarm 1 can be configured by setting A1SF = **taon** or **taof** to provide either a dwell function or a soak function to be used in conjunction with the ramp function.

5.13.1 Ramp Function

If the ramp function is selected, the process will increase or decrease at a predetermined rate during initial power up, or with setpoint changes/process variations.

The ramp rate is determined by the "RAMP" parameter which can be adjusted in the range 0 to 55.55 °C / minute (99.99 °F / minute). The ramp rate function is disabled when the "RAMP" parameter is set to "0".

In the example below the "RAMP" is set to 5.00 °C / minute, power is applied at zero time and the process value climbs to the 125 °C setpoint over a period of 20 minutes. This process temperature is held until the setpoint value is changed to 150 °C at 40 minutes. The process value then climbs to the new setpoint over a period of 5 minutes and the new setpoint is held. At 70 minutes the setpoint value is decreased to 75 °C and the process value falls to the new setpoint over a period of 15 minutes.

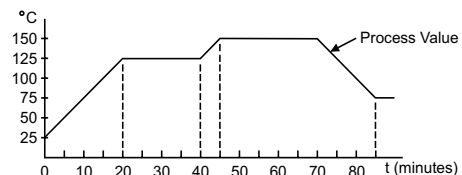

5.13.2 Ramp & Soak Function

The soak function is enabled by configuring the alarm 1 to act as a dwell timer. If A1SF is set to **Loon** (time out on), the alarm 1 relay will now operate as a timer contact, with the contact being opened at power up and closing after the elapsed time set at parameter ASP1. If A1SF is set to **Loof** (time out off), a reverse action of alarm 1 relay will perform.

If the controller power supply or output is wired through the alarm contact, the controller will operate as a guaranteed soak controller.

In the example below the " RAMP " is set to 5.00 °C / minute, A1SF = time out off, and ASP1 = 20 (minutes). Power is applied at zero time and the process climbs at 5 °C / minute to the setpoint of 125 °C. Upon reaching setpoint, the dwell timer is activated and after the soak time of 20 minutes, the alarm 1 relay will open, switching off the output. The process temperature will eventually fall at an undetermined rate.

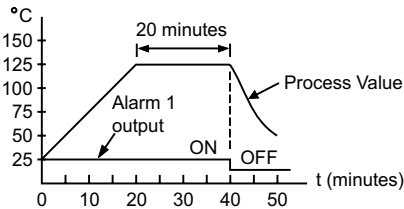

5.13.3 Dwell Function

The dwell function is enabled by configuring the alarm 1 to act as a dwell timer. If A1SF is set to **Loon** (time out on), the alarm 1 relay will now operate as a timer contact with the contact being opened on initial start up. The timer begins to count down once the setpoint temperature is reached. After the setting at ASP1 has elapsed, the alarm 1 relay closes.

The dwell function may be used to operate an external device, such as a siren to alert (for example) when a soak time has been reached.

In the example below, the ramp rate has been set to " 0 ", A1SF=**Loon** and ASP1 = 30 (minutes). Initial start up is a zero time and the process climbs to the 125 °C setpoint with a maximum rate. Once setpoint is reached, the dwell timer begins to count. After 30 minutes the alarm 1 relay closes. The controller will continue to operate as a fixed setpoint controller. Timer reset on power up only.

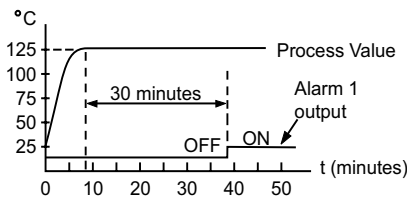

5.14 RE-RANGING LINEAR PROCESS INPUTS

Select an appropriate Input Type (INPT). Define the range by adjusting LOSC and HISC. In the example below, INPT = 4-20 (mA), LOSC = 0, HISC = 100.0, RESO = **ldP**

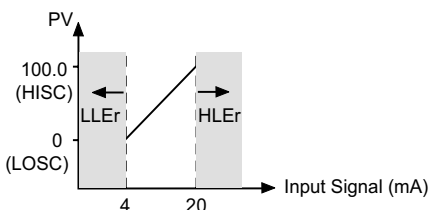

For a 4 mA input the process value will read 0 (=LOSC), and for a 20 mA input the process value will read 100.0 (HISC). For a 10 mA input the process value will read 37.5. If the input signal is beyond the limits, an error message LLEr or HLEr will be shown in the upper display.

5.15 READ PEAK PROCESS VALUES

The maximum and minimum values of the process value are continuously updated and stored in the memory as power up. Press both **Q** and **∨** to obtain " READ PEAK " Tool Program. Press scroll key to select **hi, Pu** or **LoPu** which is shown in lower display. Now the upper display will show the high peak value or low peak value of the process.

To reset the values, press and hold the scroll key for 3.2 second and release, this moment both low peak value and high peak value will be revised by the current process value.

This Tool Program provides an useful function for monitoring the stability of the process.

5.16 LOCK /UNLOCK PARAMETERS

* Lock all the parameters
press and hold both **Q** **∧** for 3.2 seconds then release, the keypad operation is disabled to protect parameters from tampering. Unlock keypad operation, press both up and down keys then release.

* Lock parameters in the same security level
Refer to section 6.6.4 for the operation

6. RE-CALIBRATION

! Do not proceed through this section unless there is a definite need to re-calibrate the controller. All previous calibration data will be lost. Do not attempt recalibration unless you have available appropriate calibration equipment. If calibration data is lost, you will need to return the controller to your supplier who may charge you a service fee to re-calibrate the controller.

* Equipment needed

- (1) Standard millivolt source with range 0-100mV, accuracy ±0.01%
- (2) Standard voltage source with range 0-10V, accuracy ±0.01%
- (3) Standard current source with range 0-20mA, accuracy ±0.01%
- (4) Standard ohm source with range 0-300 ohm, accuracy ±0.01%
- (5) Standard thermometer with range 0-50.0 °C, accuracy ±0.2 °C
- (6) A cooling fan or at the best a calibration fixture equipped with a fan and a push-button switch
- (7) Thermocouple simulator

* Calibration Setup

- (1) Select T/C input, UNIT = °C, RESO = **ldP**
- (2) Switch the power off
- (3) Disconnect the sensor wiring
- (4) Connect the input terminals of the controller to the signal sources according to the following diagram
- (5) Install a fan to blow the cold-junction compensator which is located at the rear edge of the lower PCB to prevent the cold-junction compensator from warming up

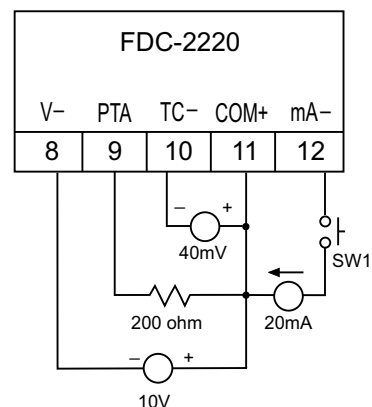

* Calibration Procedures

- (1) Press both scroll and down key, then release. Tool program will appear on the upper and lower displays. Repeat above operation until **CAL**, **A-d** appear on the displays.
- (2) Press and release the scroll key. The display will show a number with a prefix "t"
- (3) Use the up and down keys to change the value on the display until this value coincide with the ambient temperature in degree C which is measured by the standard thermometer.
- (4) Press the scroll key for at least 3.2 seconds, then release. The display will blink a moment and then show the ambient temperature in degree C.
- (5) Press and release the scroll key. The display will show a number with a prefix "A", and the display will show 0.00.
- (6) Press and hold down the push-button switch SW1. Don't release SW1. Press the scroll key for at least 3.2 seconds, then release. The display now will show 20.00. Release SW1.
- (7) Press and release the scroll key. The display will show a number with a prefix "d". If the number is not equal to 0.0, use the up and down keys to set the value to 0.0. Then press the scroll key for at least 3.2 seconds, then release. The "d" code is reset.

* Verify Calibration Accuracy

- (1) Operate the key pads until the display reaches the calibration mode (**CAL**, **A-d** appear on the displays).
- (2) Press and release the scroll key until a **A** code is shown in the display. The display will indicate process value with respect to the 0-20mA input. Feed a standard signal to the correct mA input terminals and examine the accuracy of the display.
- (3) Press and release the scroll key again until a **d** code is shown in the display. Now the display will indicate process value with respect to the INPT type selected. Feed a standard signal to the appropriate input terminals and examine the accuracy of the display.
- (4) Press **Q** and **U**, then release quickly, the display will indicate process value with respect to the PT100/DIN input. Feed a standard signal to the PT100 input terminals and examine the accuracy of the display.
- (5) Press **Q** and **U**, then release quickly, the display will indicate process value with respect to the 0-10V input. Feed a standard signal to the voltage input terminals and examine the accuracy of the display.

* Warm-up drift correction for thermocouple input after completing the above calibration procedure, connect a thermocouple to terminal 13 and 14 (observing polarity) and select a correct "INPT" for the thermocouple. Switch the power on and let the controller to be powered for at least 30 minutes. If the controller does not measure a correct temperature for the thermocouple, the following procedures may be employed to correct the error.

- (1) Perform procedure (1) and (2) stated in calibration procedures.
- (2) Press and release the scroll key.
- (3) Press and release the scroll key again. Now the "d" code with zero value is obtained on the display.
- (4) Use the up and down keys to change the "d" code value until the display shows a correct temperature. The unit of "d" code value is always in degree C independent of the selection of "UNIT".
- (5) Press the scroll key for at least 3.2 seconds, then release. The display will blink a moment and show an accurate temperature. If the accuracy of the controller is still unacceptable, replace the controller.

7. ERROR MESSAGE & DIAGNOSIS

 This procedure requires access to the circuitry of a live power unit. Dangerous accidental contact with line voltage is possible. Only qualified personnel are to perform these procedures. Potentially lethal voltages are present.

Experience has proven that many control problems are not caused by a defective instrument. See chart below and Table 7.1 for some of the other common causes of failures:

- * Line wires are improperly connected
- * No voltage between line terminals
- * Incorrect voltage between line terminals
- * Connections to terminals are open, missing or loose
- * Thermocouple is open at tip
- * Thermocouple lead is broken
- * Shorted thermocouple leads
- * Short across terminals
- * Open or shorted heater circuit
- * Open coil in external contactor
- * Burned out line fuses
- * Burned out relay inside control
- * Defective solid-state relays
- * Defective line switches
- * Burned out contactor
- * Defective circuit breakers

If the points listed on the chart have been checked and the controller does not function, it is suggested that the instrument be returned to the factory for inspection.

Do not attempt to make repairs. It usually creates costly damage. Also, it is advisable to use adequate packing materials to prevent damage in shipment.

Dismantling the controller

- (1) Press both sides of the latch located on rear terminal block. Hold tightly and remove the terminal block from the housing.
- (2) Expand the rear edge of the housing by using a tool. Pull out the PCB from the

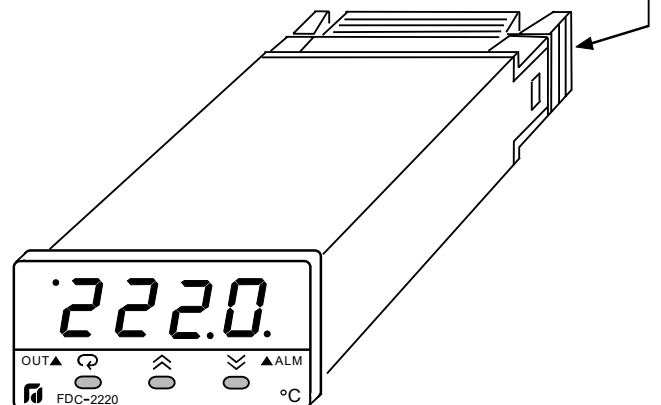

TABLE 7.1 TROUBLESHOOTING

Sympton	Probable Causes (s)	Solution (s)
1) Keypad no function	- Bad connection between PCB & keypads	- Clean contact area on PCB - Replace keypads
2) LED's will not light	- No power to instrument - Power supply defective	- Check power line connections - Replace power supply board
3) Some segments of the display or LED lamps not lit or lit erroneously.	- LED display or LED Lamp defective - Related LED driver defective	- Replace LED display or LED lamp - Replace the related transistor or IC chip
4) Process Display shows: <i>SbEr</i>	- Sensor break error	- Replace RTD or sensor - Use manual mode operation
5) Process Display shows: <i>LLEr</i>	- Input signal beyond the low range, sensor fails - Incorrect input type selected	- Replace sensor - Check sensor or thermocouple type, correct input selection
6) Process Display show: <i>HHEr</i>	- Input signal beyond the high range, sensor fails - Incorrect input type selected	- Replace sensor - Check sensor or thermocouple type, correct input selection
7) Process Display shows: <i>AdEr</i>	- A to D module damage	- Replace module. Check for outside source of damage such as transient voltage spikes.
8) Process Display shows: <i>oPEr</i>	- Incorrect operation of auto tune procedure. Prop. Band set to 0 - Manual mode is not allowable for an ON-OFF control system	- Repeat procedure. Increase Prop. Band to a number larger than 0. - Increase proportional band
9) Process Display shows: <i>CEr</i>	- Check sum error, values in memory may have changed accidentally	- Check and reconfigure the control parameters
10) Process Display shows: <i>ntEr</i>	- Fail to enter data into EEPROM	- Replace EEPROM
11) Process Display shows: <i>oYEr</i>	- Overflow error, data out of range during execution of software program	- Check if there is a noise coming in. Solve the problem by means of item (19).
12) Process Display shows: <i>LoLr</i>	- Attempt to change a locked parameter	- Unlock procedures stated in section 5.16
13) Display Unstable	- Analog portion or A-D converter defective - Thermocouple, RTD or sensor defective - Intermittent connection of sensor wiring	- Replace related components or board - Check thermocouple, RTD or sensor - Check sensor wiring connections
14) Considerable error in temperature indication	- Wrong sensor or thermocouple type. Wrong input mode selected. - Analog portion A-D converter defective	- Check sensor or thermocouple type and if proper input mode was selected - Replace related components or board
15) Display goes in reverse direction (counts down scale as process warms)	- Reversed input wiring of sensor	- Check and correct
16) No heat or output	- No heater power (output), incorrect output device used - Output device defective - Open fuse outside of the instrument	- Check output wiring and output device - Replace output device - Replace output fuse
17) Heat or output stays on but indicator reads normal	- Output device shorted, or power service shorted	- Check and replace
18) Control abnormal or operation incorrect	- CPU or EEPROM (non-volatile memory) defective. Key switch defective - Operation of control incorrect	- Check and replace - Read the operation procedure carefully
19) Display blinks, entered values change by themselves	- Electromagnetic interference (EMI), or Radio Frequency interface (RFI) - EEPROM defective	- Suppress arcing contacts in system to eliminate high voltage spike sources. Separate sensor and controller wiring from "dirty" power lines, ground heaters - Replace EEPROM

8.0 COMMON FAILURE CAUSES

Common Failure Causes and Corrective Actions

Symptom	Probable Causes	Corrective Actions
1) Keypad no function	-Bad connection between PCB & keypads	- Clean contact area on PCB - Replace keypads
2) LED's will not light	- No power to instrument - Power supply defective	- Check power line connections - Replace power supply board
3) Some segments of the display or LED lamps not lit or lit erroneously.	- LED display or LED lamp defective - Related LED driver defective	- Replace LED display or LED lamp - Replace the related transistor or IC chip
4) Display Unstable	- Analog portion or A-D converter defective - Thermocouple, RTD or sensor defective - Intermittent connection of sensor wiring	- Replace related components or board - Check thermocouple, RTD or sensor - Check sensor wiring connections
5) Considerable error in temperature indication	- Wrong sensor or thermocouple type, wrong input mode selected. - Analog portion of A-D converter defective	- Check sensor or thermocouple type and if proper input mode was selected - Replace related components or board
6) Display goes in reverse direction (counts down scale as process warms)	- Reversed input wiring of sensor	- Check and correct
7) No heat or output	- No heater power (output), incorrect output device used - Output device defective - Open fuse outside of the instrument	- Check output wiring and output device - Replace output device - Replace output fuse
8) Heat or output stays on but indicator reads normal	- Output device shorted, or power service shorted	- Check and replace
9) Control abnormal or operation incorrect	- CPU or EEPROM (non-volatile memory) defective. Key switch defective - Incorrect setup values	- Check and replace - Read the setup procedure carefully
10) Display blinks; entered values change by themselves	- Electromagnetic interference (EMI), or Radio Frequency interference (RFI) - EEPROM defective	- Suppress arcing contacts in system to eliminate high voltage spike sources. Separate sensor and controller wiring from " dirty " power lines, ground heaters - Replace EEPROM